

## System separator for 3D printing machinery / additive manufacturing for pre-cooling in existing and/or new plants.

---

**Uncomplicated.** No conversion necessary in the existing system. All components required for the fully automatic cooling process are included in the system separator.

---

**Simple.** Plug & Play Solution. Simple retrofit. Simple installation.

---

**Reliable and compact.** Maximum redundancy and operational reliability guaranteed.

---

**Flexibly duplicatable.** Depending on the size of the machine park, a flexible number of system separators can be used.

---

**Sustainable.** No need to replace the entire cooling system. Energy-saving and sustainable with high customer benefit and minimal footprint.

---

# Ready-to-connect system separators with precise cooling capacity.

## For 3D printing machine parks / additive manufacturing.

Riedel Kooling system separators are reliable and compact. Ideal for use in the additive industry, where precise cooling and high operational reliability are essential. System separators from Riedel Kooling are ready for connection and can be easily put into operation via plug & play without major modification of the existing system. All components required for the fully automatic cooling process are included in the system separator. It does not matter how many system separators are integrated in the overall system - the number can be flexibly duplicated/expanded. Individually adapted to the size of the machine park and perfectly tailored to the customer's requirements. The Riedel Kooling solution eliminates the need to replace the entire cooling system. The sustainable concept operates in an energy-saving manner and offers real customer benefits with a minimal footprint.

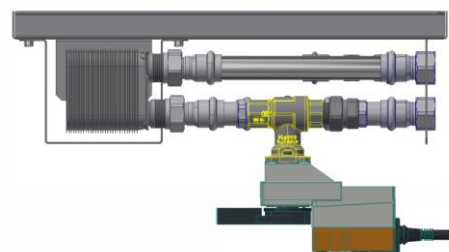
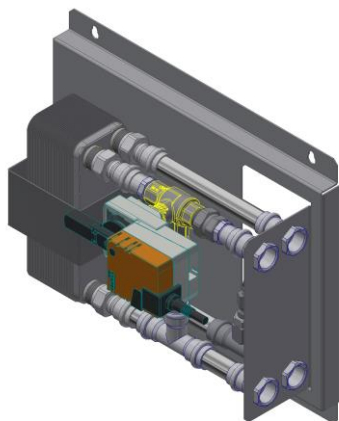
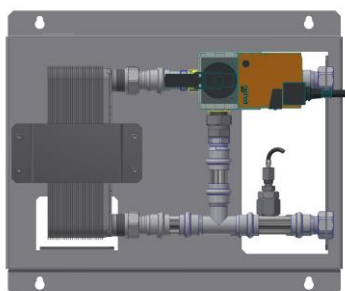

Riedel Kooling System separator

### Functional diagram.

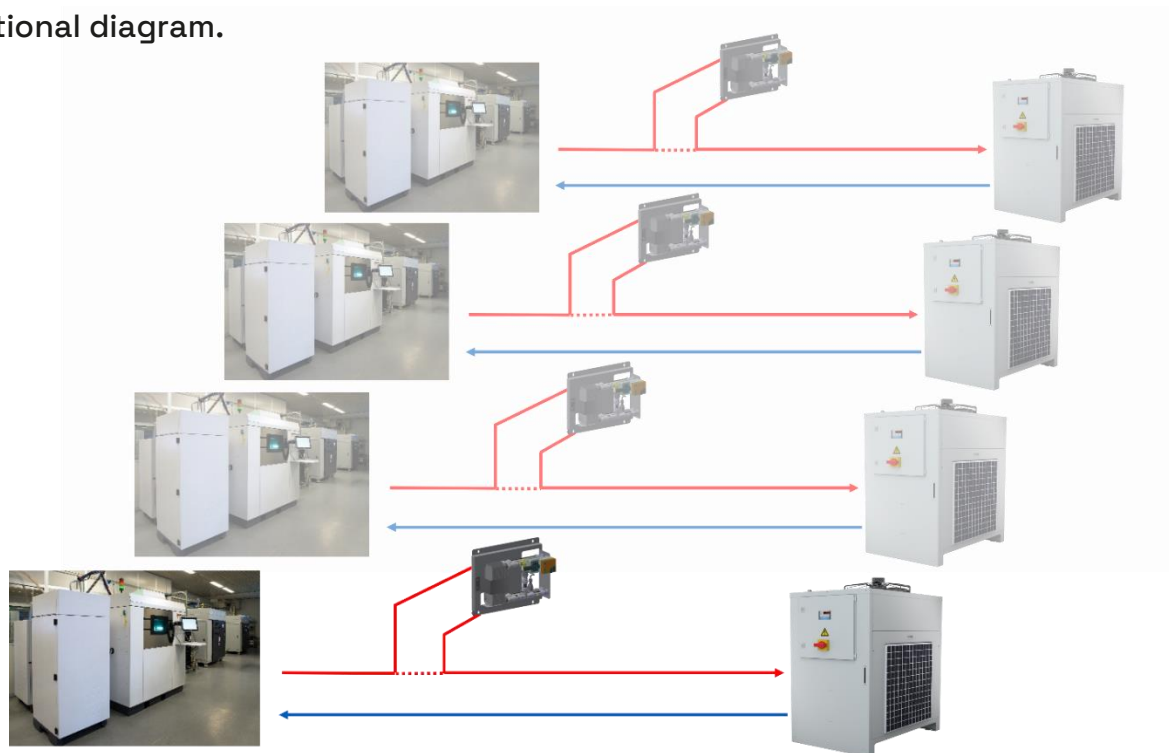

**Sales Riedel Kooling**  
Glen Dimplex Deutschland GmbH  
Am Goldenen Feld 18  
95326 Kulmbach  
Germany  
T + 49 9221 709-555  
info@riedel-kooling.com

**24/7 Service**  
T + 49 9221 709-545  
service@riedel-kooling.com

**Visit:**  
[riedel-kooling.com](http://riedel-kooling.com)